



Project Name \_\_\_\_\_

Date \_\_\_\_\_ Type \_\_\_\_\_

Notes \_\_\_\_\_

### APPLICATIONS

Lighting installations for side and top mounting of luminaires with effective projected area (EPA) not exceeding maximum allowable loading of the specified pole in its installed geographic location.

### CONSTRUCTION

**Shaft:** One-piece; tapered steel with square cross section, ASTM A595 Grade A Steel; Longitudinal weld seam to appear flush in shaft wall; Steel base plate with bolt circle holes welded to pole shaft having minimum yield of 36,000 psi (ASTM A36) Pole shafts taper at .11"/ft.

**Anchor Bolts:** Supplied with (4) galvanized anchor bolts with minimum yield of 55,000 psi (ASTM F1554). Galvanized hardware with two washers and two nuts per bolt for leveling

**Base Cover:** Two-piece square base cover standard

**Pole Cap:** Pole shaft supplied with removable cover when applicable; Tenon and post-top configurations also available

**Hand Hole:** 20' and 25' Poles: 3" X 5" handhole opening. Poles 30' and above have 4" X 6.5" handhole opening with cover and grounding provision. The center of the handhole is located 18" from the base of the pole.

### FINISH

- Durable thermoset polyester powder coat paint finish with nominal 3.0 mil thickness
- Decorative finish coat available in three standard colors; Custom colors available; RAL number preferable

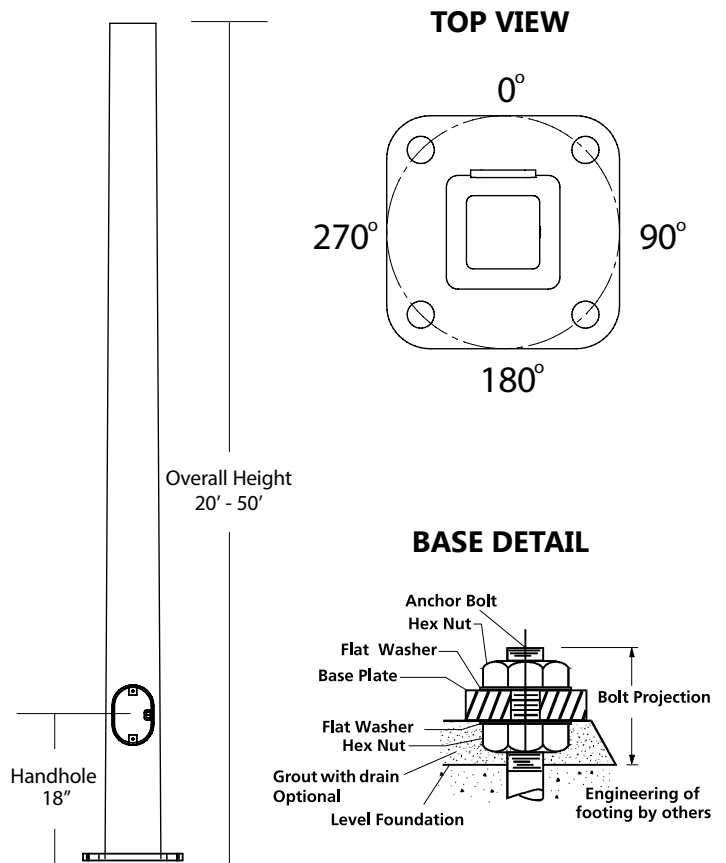

### POLE CAP

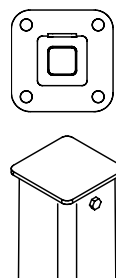

### TENON

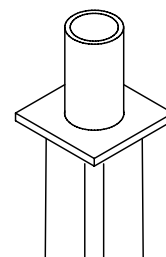

### BASE COVER

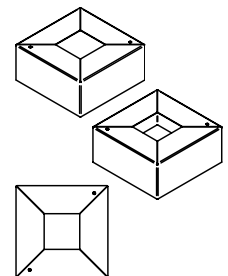

## STSE Series Poles

Square | Tapered | Steel

### Ordering Information

Project Name \_\_\_\_\_

Date \_\_\_\_\_ Type \_\_\_\_\_

Notes \_\_\_\_\_

### Example: STSE20-50A-2-E2-DKBZ-VM2

## STSE

## E2

SERIES	HEIGHT	SHAFT	THICKNESS	MOUNTING	POLE DRILLING	FINISH	OPTIONS
STSE = Evolve Square Tapered Steel Pole	20=20 ft.	50=5.25x3.05"	A=.119"	<b>1</b> = Single arm mount <b>2</b> = Two fixtures at 180° <b>TA</b> = Tenon (2.375" OD) <b>TB</b> = Tenon (2.875" OD) <b>OT</b> = Open Top (includes pole cap)	E2 = Evolve Square Pole	<b>DKBZ</b> = Dark Bronze <b>BLCK</b> = Black <b>GRAY</b> = Gray <i>* Contact factory for custom color options</i>	<b>GFI</b> <sup>1</sup> = Provisions for GFC Receptacle <b>EHH</b> <sup>1</sup> = Extra Handhole <b>C05</b> <sup>1</sup> = 0.5" Coupling <b>C07</b> <sup>1</sup> = 0.75" Coupling <b>C20</b> <sup>1</sup> = 2" Coupling <b>VM2</b> = 2nd mode vibration damper <b>LAB</b> = Less Anchor Bolts
	25=25 ft.	60=6.0x3.25"	A=.119"				
	30=30 ft.	60=6.41x3.11"	A=.119"				
	35=35 ft.	70=6.81x2.96"	A=.119"				
	40=40 ft.	70=7.13x2.87"	B=.179"				
	45=45 ft.	80=7.88x2.93"	B=.179"				
	90=8.75x3.80"	B=.179"					
	50=50 ft.	90=8.81x3.31"	B=.179"				

<sup>1</sup> Specify option location using MOUNTING ORIENTATION logic shown below

## MOUNTING ORIENTATION

 Denotes handhole location

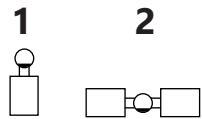

CATALOG NUMBER	HEIGHT		NOMINAL SHAFT DIMENSIONS	WALL THICKNESS	BOLT CIRCLE	BASE PLATE SQUARE	ANCHOR BOLT SIZE	BOLT PROJECTION	POLE WEIGHT
	FEET	METERS							
STSE20-50A	20	6.1	5.25" x 3.05"	0.119"	10.75"	10.75"	1"x36"x4"	4.00"	155
STSE25-60A	25	7.6	6.00" x 3.25"	0.119"	12.00"	11.50"	1"x36"x4"	4.13"	205
STSE30-60A	30	9.1	6.41" x 3.11"	0.119"	12.50"	11.88"	1"x36"x4"	4.13"	260
STSE35-70A	35	10.7	6.81" x 2.96"	0.119"	13.00"	12.25"	1"x36"x4"	4.13"	305
STSE40-70B	40	12.2	7.13" x 2.87"	0.179"	13.50"	12.63"	1"x36"x4"	4.50"	500
STSE45-80B	45	13.7	7.88" x 2.93"	0.179"	14.50"	13.68"	1"x36"x4"	4.50"	620
STSE45-90B	45	13.7	8.75" x 3.80"	0.179"	15.75"	14.25"	1.25"x42"x6"	5.25"	730
STSE50-90B	50	15.2	8.81" x 3.31"	0.179"	16.00"	15.50"	1.25"x42"x6"	5.00"	780

**NOTES:**  
 1. Factory supplied template must be used when setting anchor bolts. Current will deny any claim for incorrect anchorage placement resulting from failure to use factory supplied template and anchor bolts.

### EHH EXTRA HANDHOLE

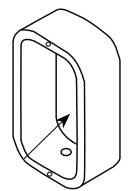

Provision for Grounding

### C05 - C07 - C20 - COUPLING

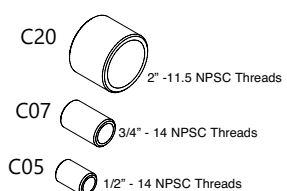

### VM2 - VIBRATION DAMPER 2ND MODE

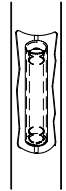

Factory installed, internal damper designed to alter pole resonance to reduce movement and material fatigue caused by 2nd mode vibration.

### OPTION ORIENTATION

Follow the logic below when ordering location specific options. For each option, include its orientation (in degrees) and its height (in feet).  
**Example:** Option C07 should be ordered as: STSE20-40A-TA-E2-DBT-C07-0-15 (.5" coupling on the handhole/arm side of pole, 15 feet up from the pole base) 1' spacing required between option. Consult factory for other configurations.

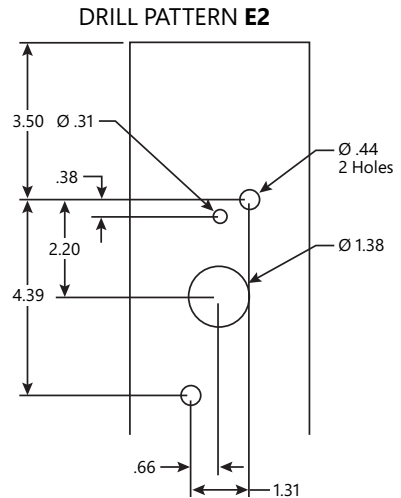
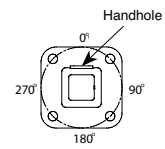
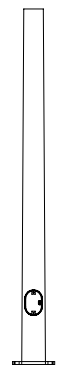

## STSE Series Poles

Square | Tapered | Steel

EPA Load Rating - Wind Maps

Project Name \_\_\_\_\_

Date \_\_\_\_\_ Type \_\_\_\_\_

Notes \_\_\_\_\_

**ASCE7-05 WIND MAP**

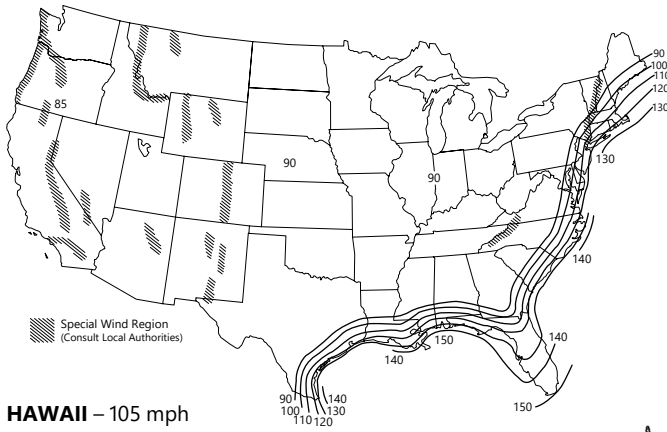

**HAWAII** – 105 mph  
**PUERTO RICO** – 145 mph

\*Printed with permission from ASCE

**FLORIDA REGION WIND MAP**

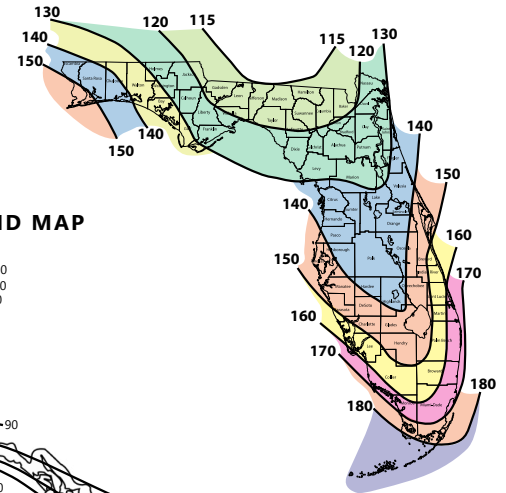

Florida region wind map above is based upon 3-second gust winds and the 2017 Florida Building Code

**ALASKA REGION WIND MAP**

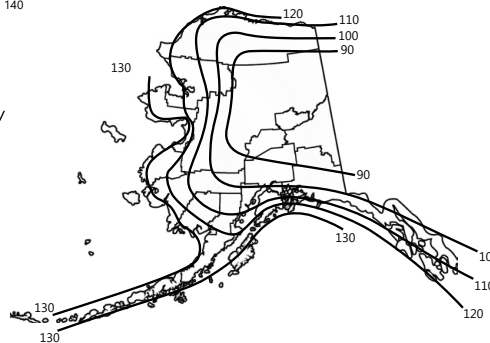

ASCE 7-05 wind map EPA Load Rating - 3 second gust wind speeds (Use for all locations except Florida)									
Catalog Number	Height	85	90	100	110	120	130	140	150
STSE20-50A	20	16.4	14.0	10.5	7.6	5.4	3.6	2.2	1.0
STSE25-60A	25	12.8	10.4	7.0	4.4	2.2	NR	NR	NR
STSE30-60A	30	8.5	6.6	3.4	1.0	NR	NR	NR	NR
STSE35-70A	35	4.8	3.0	NR	NR	NR	NR	NR	NR
STSE40-70B	40	13.5	10.8	6.4	3.0	NR	NR	NR	NR
STSE45-80B	45	7.5	5.0	1.0	NR	NR	NR	NR	NR
STSE45-90B	45	12.4	9.4	3.6	NR	NR	NR	NR	NR
STSE50-90B	50	8.0	5.4	NR	NR	NR	NR	NR	NR

Florida Building Code 2017 EPA Load Rating - 3 second gust wind speeds									
Catalog Number	Height	115	120	130	140	150	160	170	180
STSE20-50A	20	14.0	12.2	10.0	7.7	6.0	4.5	3.2	2.0
STSE25-60A	25	10.5	9.0	6.5	4.5	2.7	1.5	NR	NR
STSE30-60A	30	6.5	5.0	3.0	1.2	NR	NR	NR	NR
STSE35-70A	35	3.0	1.7	NR	NR	NR	NR	NR	NR
STSE40-70B	40	11.0	9.2	6.0	3.5	NR	NR	NR	NR
STSE45-80B	45	5.5	3.7	0.8	NR	NR	NR	NR	NR
STSE45-90B	45	9.5	7.2	3.0	NR	NR	NR	NR	NR
STSE50-90B	50	5.5	3.0	NR	NR	NR	NR	NR	NR

### NOTES

1. Allowable EPA, to determine max pole loading weight, multiply allowable EPA by 30 lbs.
2. The tables for allowable pole EPA are based on the ASCE 7-05 Wind Map or the Florida Region Wind Map for the 2017 Florida Building Code. The Wind Maps are intended only as a general guide and cannot be used in conjunction with other maps. Always consult local authorities to determine maximum wind velocities, gusting and unique wind conditions for each specific application
3. Allowable pole EPA for jobsite wind conditions must be equal to or greater than the total EPA for fixtures, arms, and accessories to be assembled to the pole. Responsibility lies with the specifier for correct pole selection. Installation of poles without luminaires or attachment of any unauthorized accessories to poles is discouraged and shall void the manufacturer's warranty
4. Wind speeds and listed EPAs are for ground mounted installations. Poles mounted on structures (such as bridges and buildings) must consider vibration and coefficient of height factors beyond this general guide; Consult local and federal standards
5. Wind Induced Vibration brought on by steady, unidirectional winds and other unpredictable aerodynamic forces are not included in wind velocity ratings. Consult Current's Pole Vibration Application Guide for environmental risk factors and design considerations: <http://images.salsify.com/image/upload/s--Uk0Lfj10--/bf7prkg0aey64uqoipso>
6. Extreme Wind Events like, Hurricanes, Typhoons, Cyclones, or Tornadoes may expose poles to flying debris, wind shear or other detrimental effects not included in wind velocity ratings

**Due to our continued efforts to improve our products, product specifications are subject to change without notice.**